

SCALE 1:15

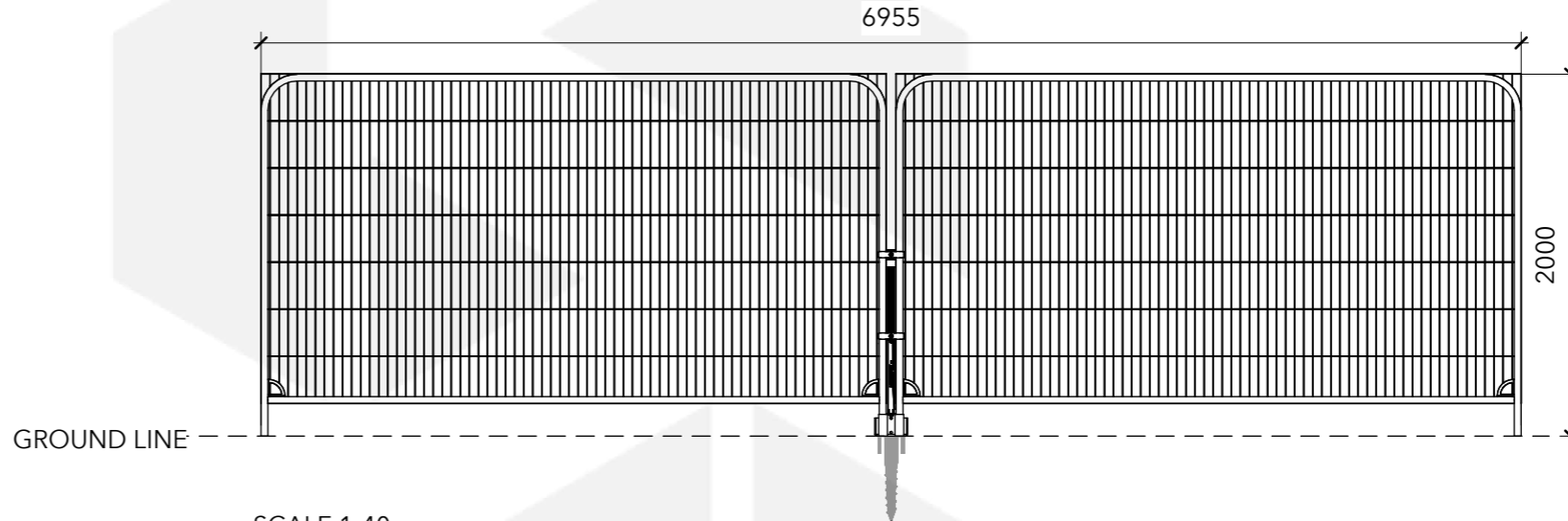

SCALE 1:40

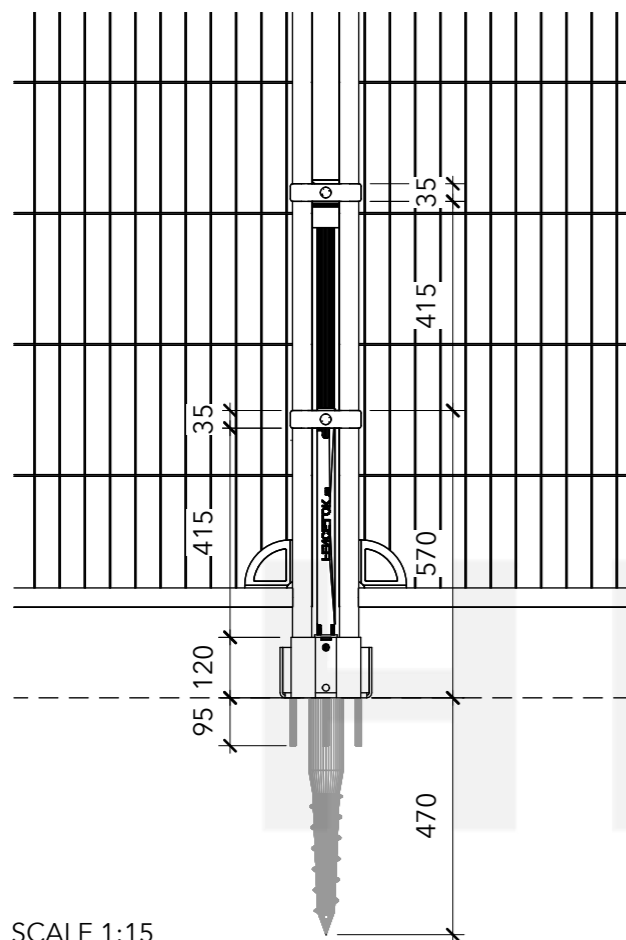

SCALE 1:15

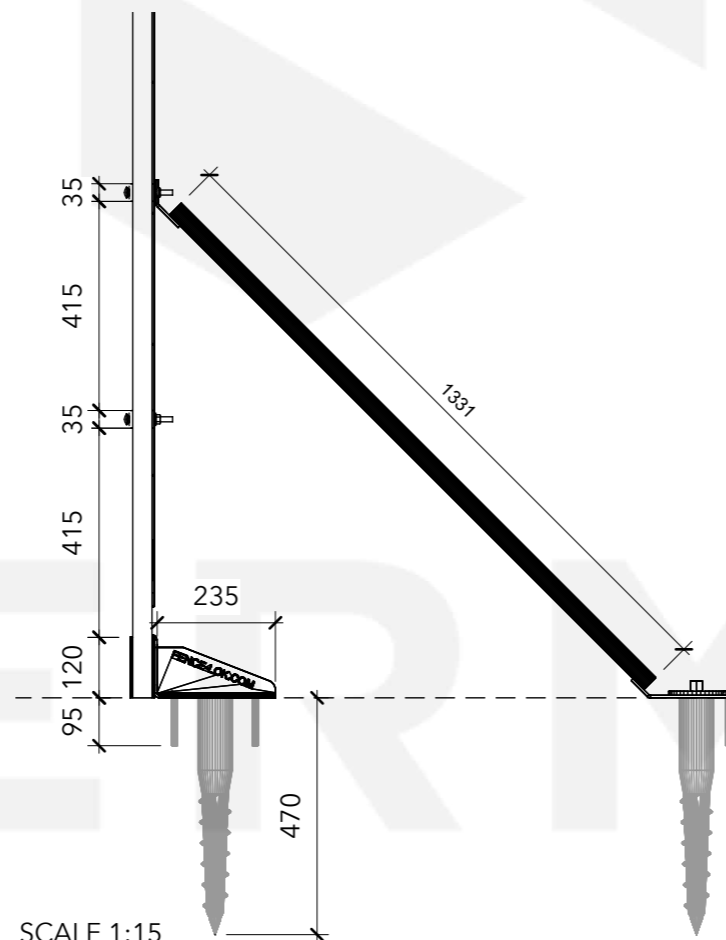

SCALE 1:15

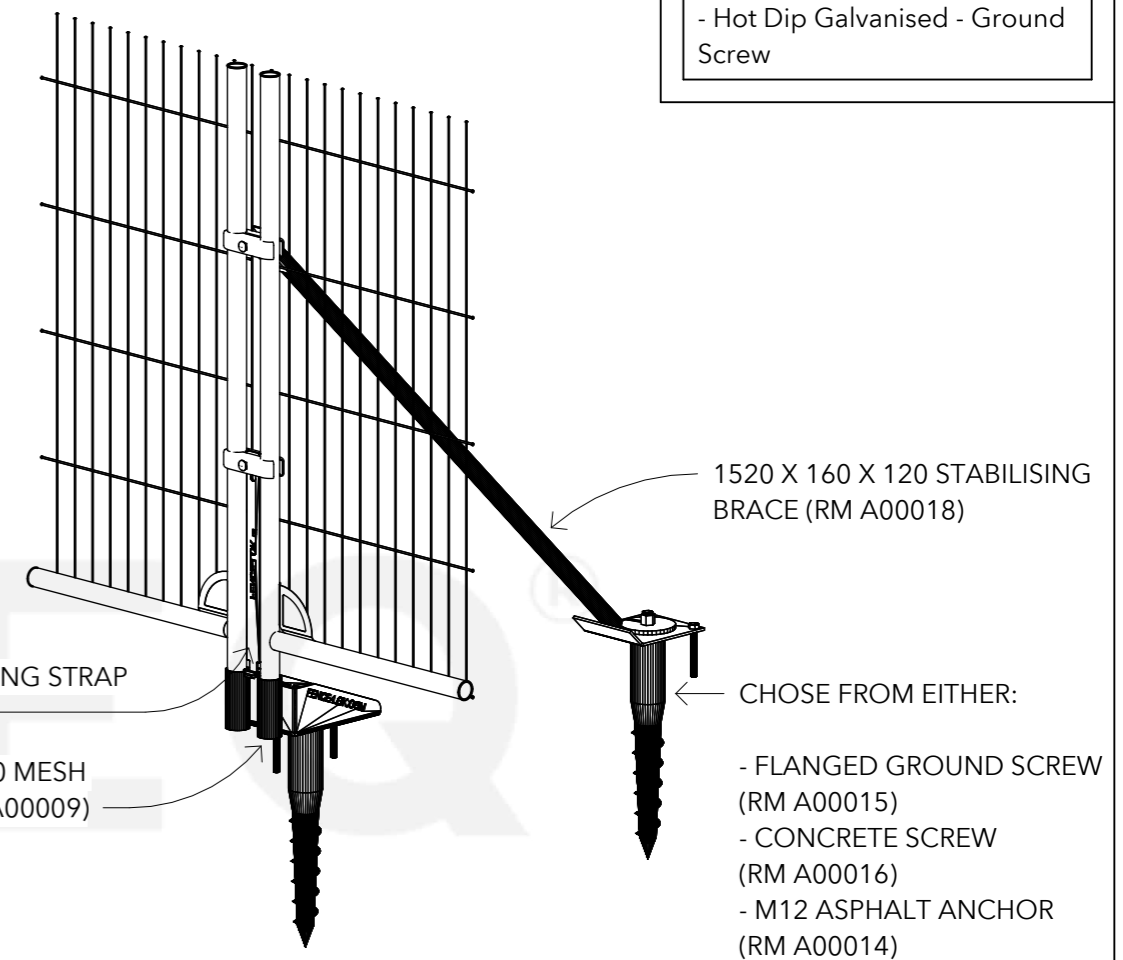

General Comments

See Our Associated Products:
[Temporary Mesh Fencing Panel](#)
[Mesh Pedestrian Gate - Standalone](#)
[Square Top Mesh Panel](#)

Materials

- Powder Coated - Mesh
- Bracket, Locking Strap
- Zinc Plated - Stabilising Brace, Concrete Screw, Asphalt Anchor
- Hot Dip Galvanised - Ground Screw



No.	Description	Date

Item	Component Description	Quantity
RM A00009	G5MM - 290MM X 180MM X 120MM MESH BRACKET	1
RM A00010	G4MM - 35MM X 460MM LOCKING STRAP	1
RM A00018	G5MM - 1520MM X 160MM X 120MM STABILISING BRACE	1
Choose One Option From The Following:		
RM A00015	FLANGED GROUND SCREW	2
RM A00016	CONCRETE SCREW	4
RM A00014	M12 ASPHALT ANCHOR	4

FENCE-LOK FENCE FEET STABILISED LOCKING SYSTEM			
Weight	N/A	Serial Number	Revision
Date	05/09/2023	A105558	
Drawn by	JT		
Checked by	Checker	Scale	As indicated @A3